

6" NOZZLE DETAIL

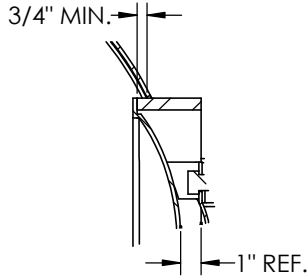

MANWAY DETAIL



ITEM NO.	PART NO.	DESCRIPTION	QTY.
1	311387-SL1	SHELL LAYOUT FOR 41" TANK	1
2	311387-SL2	SHELL LAYOUT FOR 41" TANK	1
3	H46758	41" O.D. HEMI HEAD JOGGLED	2
4	F10400	3"-NPT HALF COUPLING	1
5	F10370	1"-NPT FLAT FLANGE	2
6	F31826	1/4"-NPT FLAT FLANGE	1
7	F30263	1"-NPT RADIAL FLANGE	2
8	A99220	6" 150# ANSI, S/80 PIPE, RFSO FLANGE	2
9	A84390.48	6" PIPE BACKING RING	2
10	A72305	12" X 16" X 3/4" X 4" 300# MANWAY	1
11	A85015	1/2" X 4" X 4" LIFT LUG	4
12	A99466	BASERING ASY.	1
13	A20910.3	ASME DATA PLATE	1

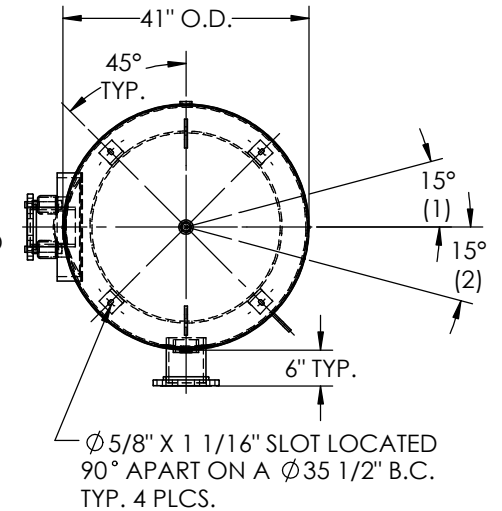
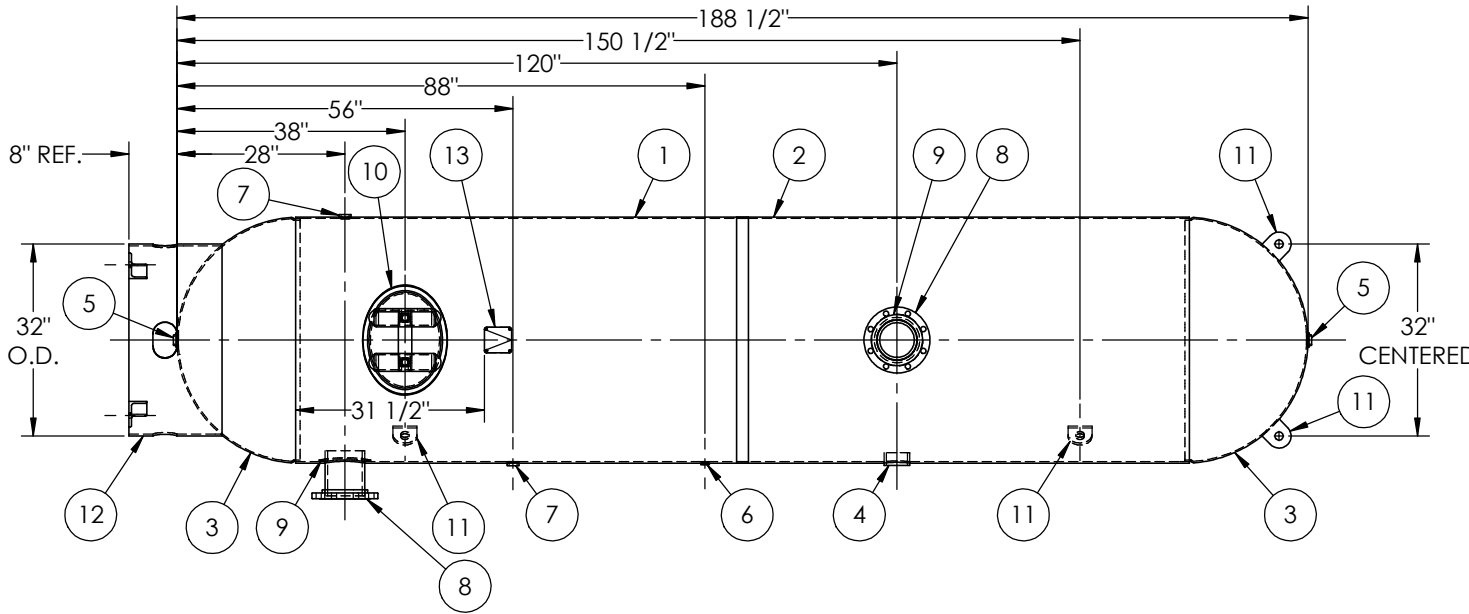

- NOTES:
- BREAK ALL EXPOSED INTERIOR NOZZLE EDGES.
 - FLANGE BOLT HOLES SHOULD STRADDLE VESSEL CENTERLINES.
 - LS WELD AT CRIMPED SECTION OF SHELL TO BE EXAMINED VIA MAG PARTICLE OR DYE PENETRANT METHOD.

SPECIFICATIONS	
O.D. 41 LGTH. 188.5	MAWP 200 PSI @ 400°F
WT. 2040 LBS.	
S.A. 174 SQ.FT.	
GAL. 1000 CU.FT. 135.4 CRN: N/A	
CODE: ASME Section VIII, Div.1, LATEST EDITION	EXMT UG-20(f) CORR ALW 0 SH 0 HD
STD. TOLERANCES: M-2461 (UNLESS OTHERWISE NOTED)	WELD DETAILS: M-1932



VERTICAL AIR RECEIVER

DRAWN BY:	DATE:
APPR. BY:	DATE:
SCALE: NONE	DRWG NO. 311387

RELEASED FOR PRODUCTION
Q.C. _____ DATE _____



REVISIONS			
REV.	BY	DESCRIPTION	DATE APP.