

THIS DRAWING & SPECIFICATIONS ARE PROPERTY OF MORGANTON PRESSURE VESSELS AND MAY NOT BE COPIED, REPRODUCED, OR USED IN WHOLE OR PART, AS A BASIS FOR DESIGN, MANUFACTURE, OR SALE WITHOUT PRIOR PERMISSION FROM MORGANTON PRESSURE VESSELS.

DESIGN INFORMATION	
SPECIFICATION	VALUE
DIAMETER (O.D.)	36.000"
MAWP	165 PSI AT 650°F
MDMT	-20°F AT 165 PSI
CAPACITY	APPROX 400 GALLONS
APPROX. WEIGHT	708 LBS

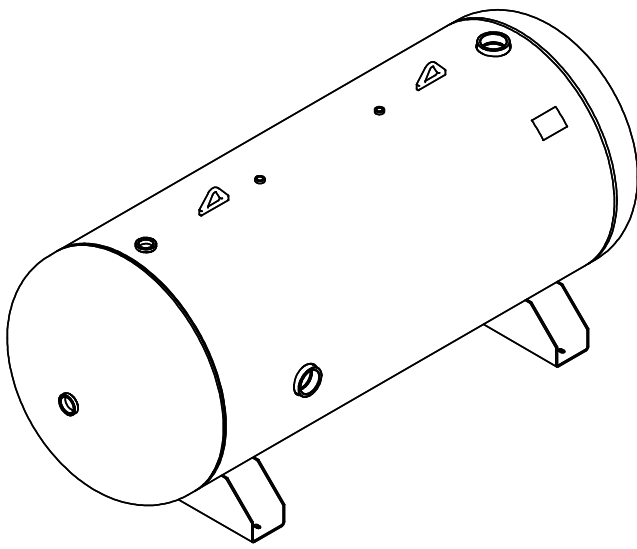
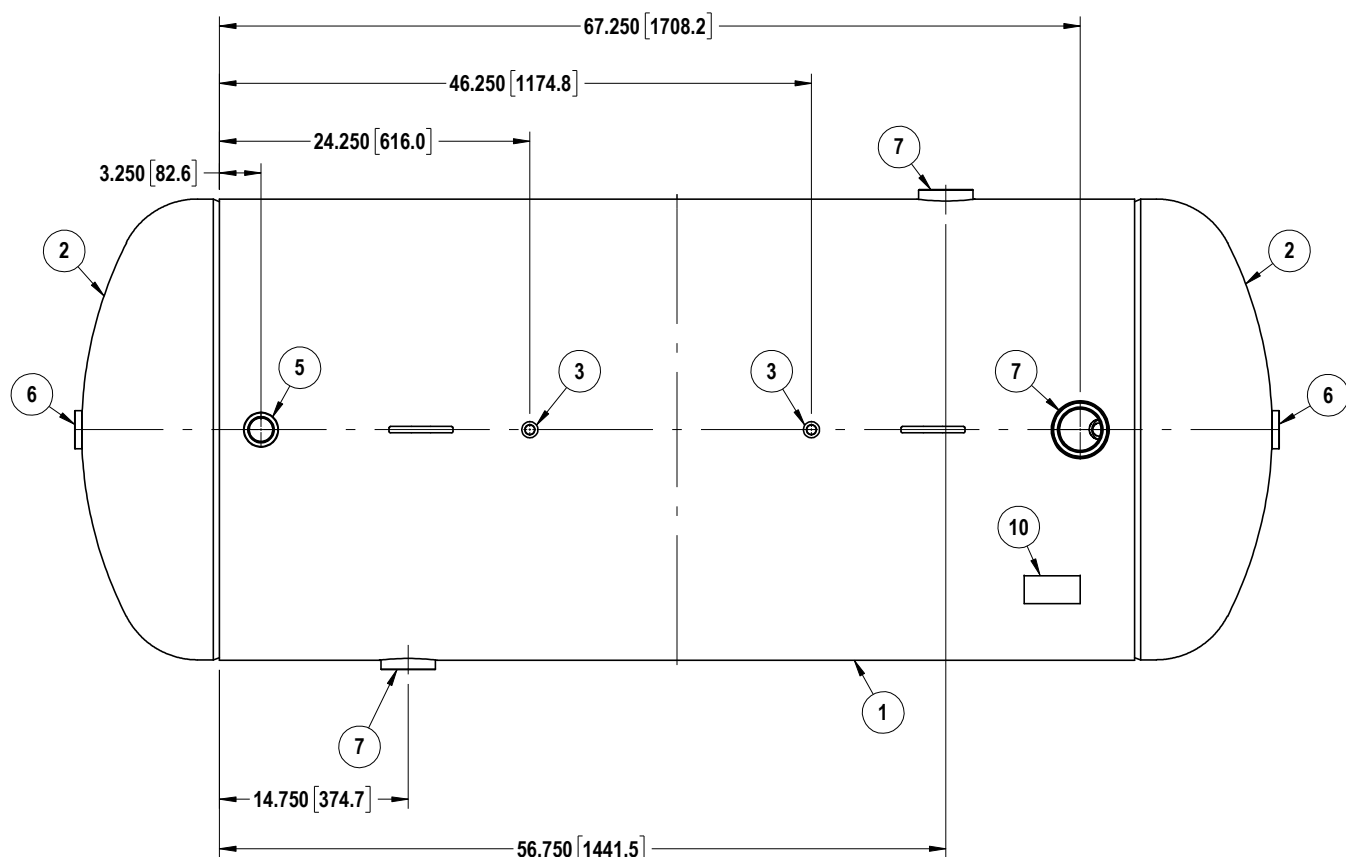
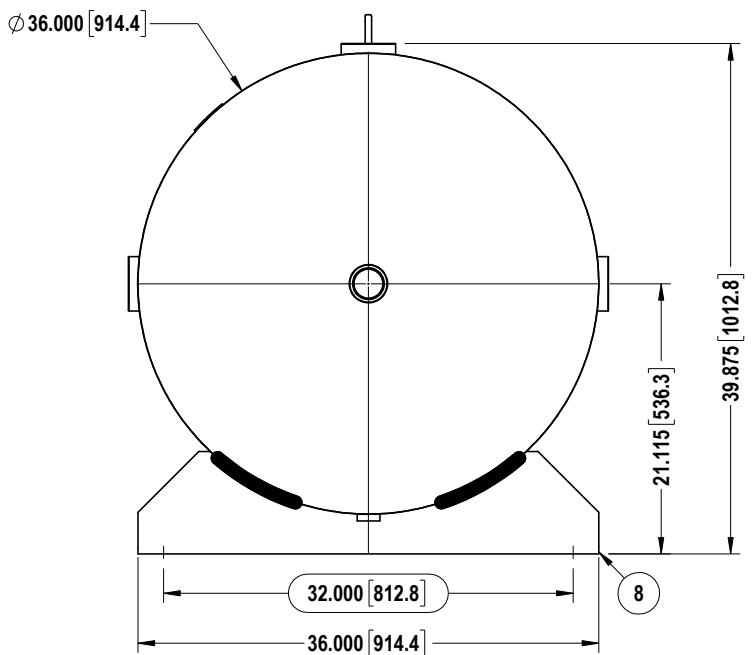
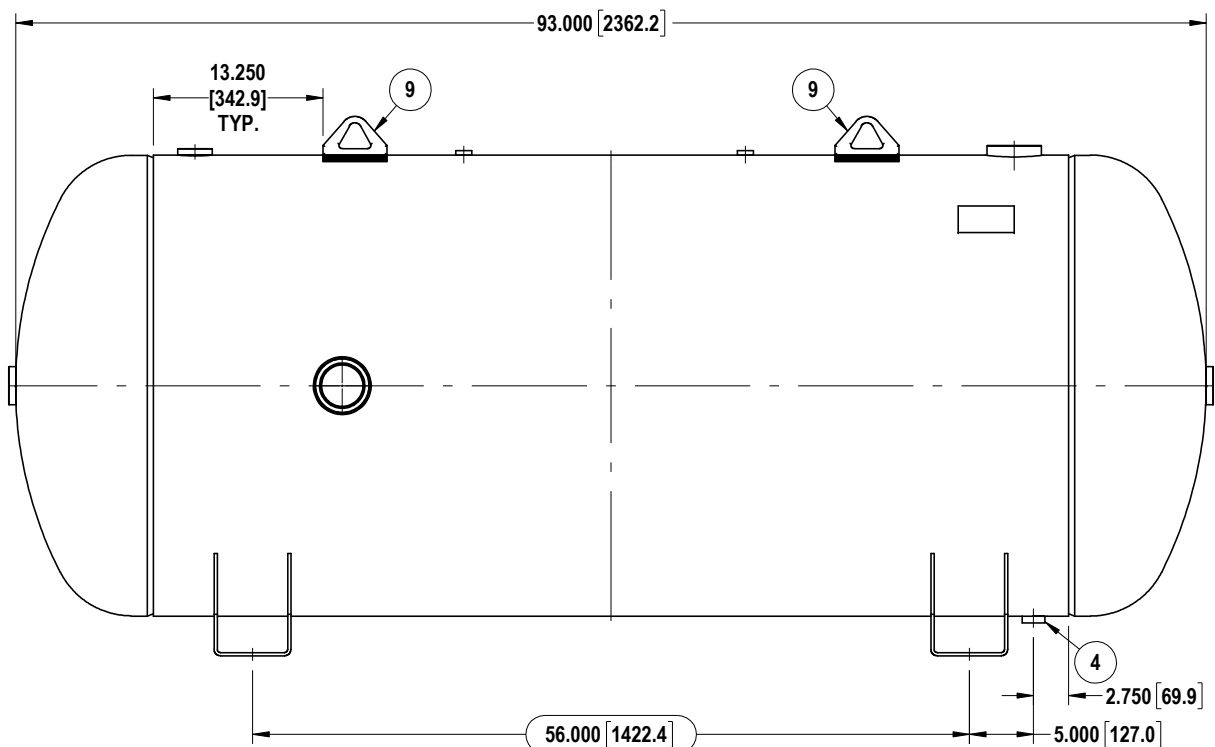

ITEM#	DESCRIPTION	QTY.
10	NAME PLATE	1
9	LIFTING LUG	2
8	SADDLE	2
7	3" NPT HALF COUPLING	3
6	2" NPT COUPLING	2
5	1-1/2" NPT COUPLING	1
4	3/4" NPT COUPLING	1
3	1/2" NPT COUPLING	2
2	HEAD	2
1	SHELL	1

<p><b>MORGANTON</b> -ASME- SECTION VIII DIV. 1 400 GALLON HORIZONTAL VESSEL</p>	<p>TOLERANCES, IF NOT INDICATED, ACCORDING TO: C-G SE 03.03 / 3</p>
	<p>DWG. NO. <b>VES0010575</b></p>
	<p><b>NOT FOR PRODUCTION USE</b></p>