

THIS DRAWING & SPECIFICATIONS ARE PROPERTY OF MORGANTON PRESSURE VESSELS AND MAY NOT BE COPIED, REPRODUCED, OR USED IN WHOLE OR PART, AS A BASIS FOR DESIGN, MANUFACTURE, OR SALE WITHOUT PRIOR PERMISSION FROM MORGANTON PRESSURE VESSELS.

DESIGN INFORMATION	
SPECIFICATION	VALUE
DIAMETER (O.D.)	20.000"
MAWP	300 PSI AT 650°F
MDMT	-20°F AT 300 PSI
CAPACITY	APPROX 60 GALLONS
APPROX. WEIGHT	260 LBS

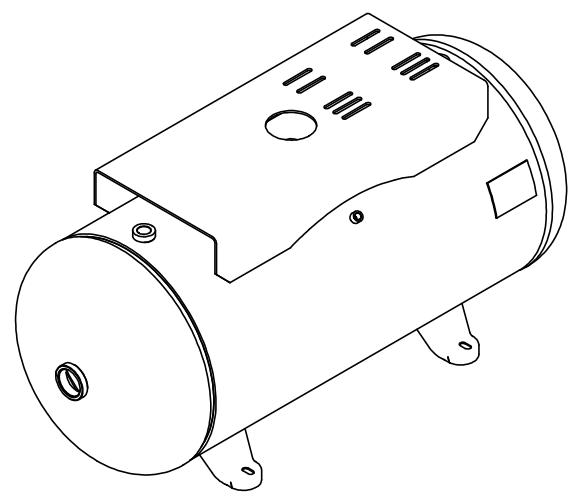
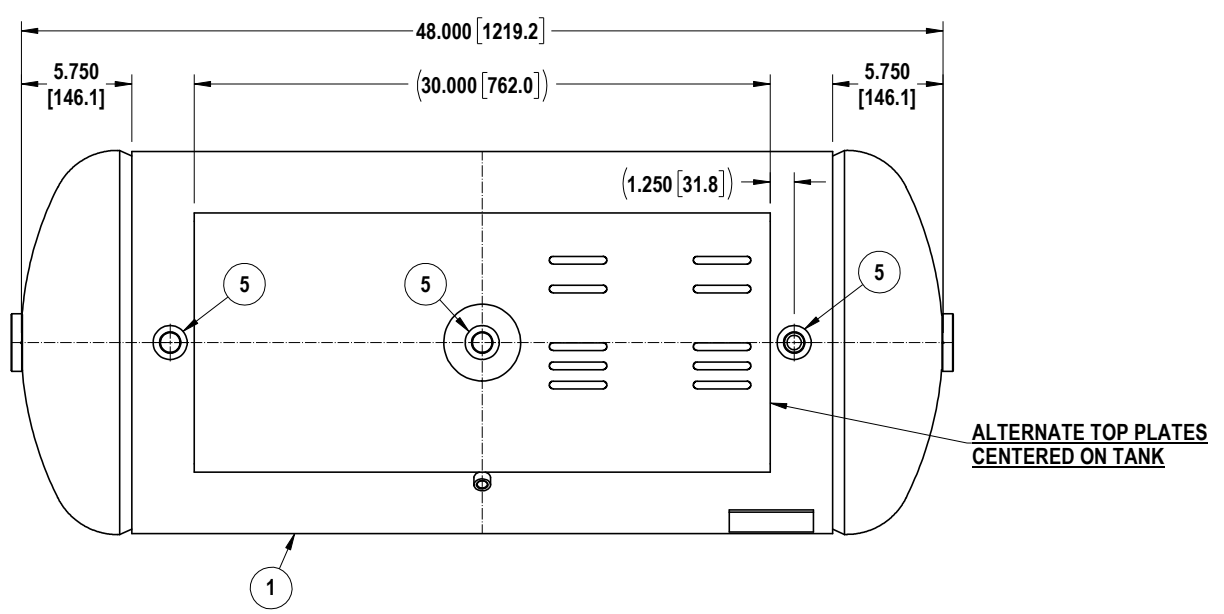
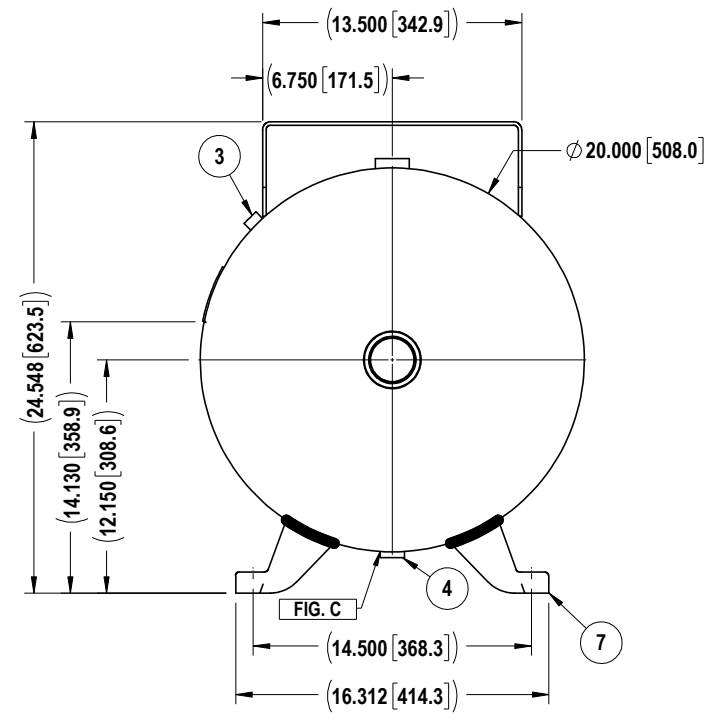
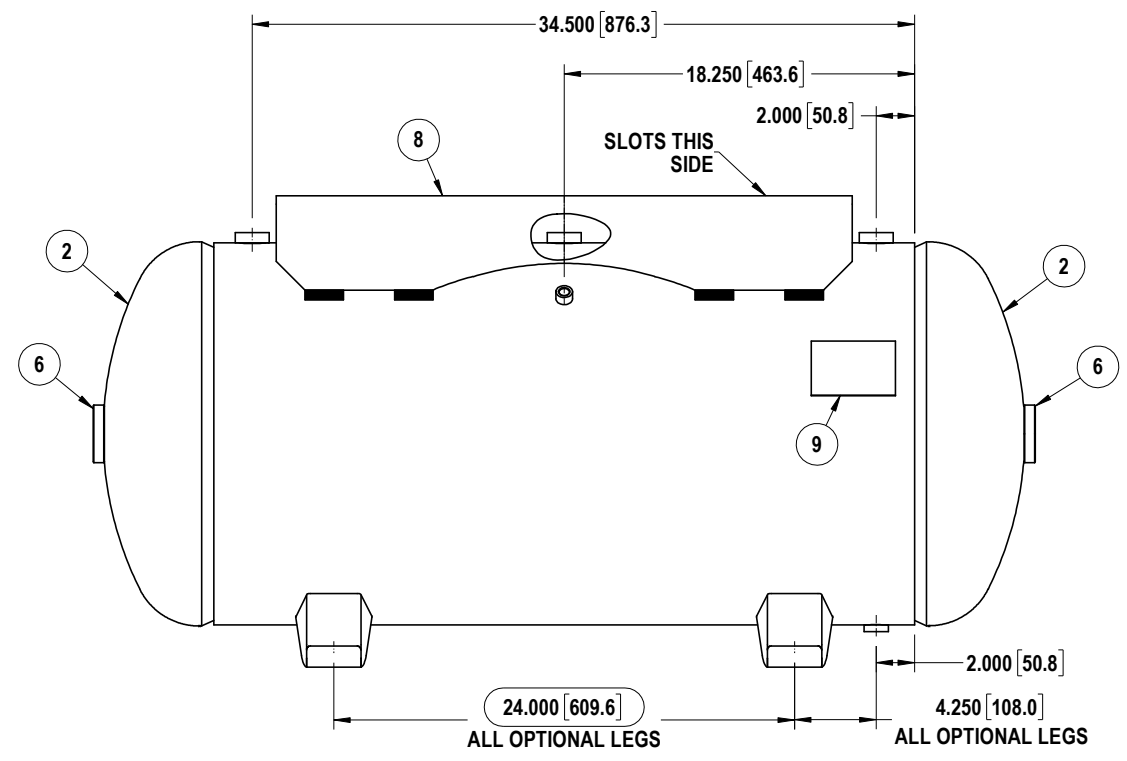

ITEM#	DESCRIPTION	QTY.
9	NAME PLATE	1
8	OPTIONAL TOP PLATE	1
8	TOP PLATE	1
7	OPTIONAL LEG	1
7	LEG	4
6	2" NPT COUPLING	2
5	3/4" NPT COUPLING	3
4	1/2" NPT COUPLING	1
3	1/4" NPT COUPLING	1
2	HEAD	2
1	SHELL	1

NOT FOR PRODUCTION USE

MORGANTON -ASME- SECTION VIII DIV. 1 60 GALLON HORIZONTAL AIR RECEIVER	TOLERANCES, IF NOT INDICATED, ACCORDING TO: C-G SE 03.03 / 3
	DWG. NO. VES0010792
	NOT FOR PRODUCTION USE