

THIS DRAWING & SPECIFICATIONS ARE PROPERTY OF MORGANTON PRESSURE VESSELS AND MAY NOT BE COPIED, REPRODUCED, OR USED IN WHOLE OR PART, AS A BASIS FOR DESIGN MANUFACTURE OR SALE WITHOUT PRIOR PERMISSION FROM MORGANTON PRESSURE VESSELS.

DESIGN INFORMATION	
SPECIFICATION	VALUE
DIAMETER (O.D.)	14.000"
MAWP	200 PSI AT 650°F
MDMT	-20°F AT 200 PSI
CAPACITY	APPROX 20 GALLONS
APPROX. WEIGHT	67 LBS

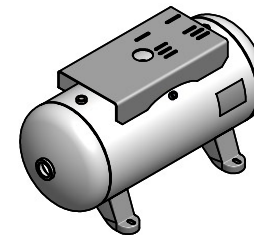
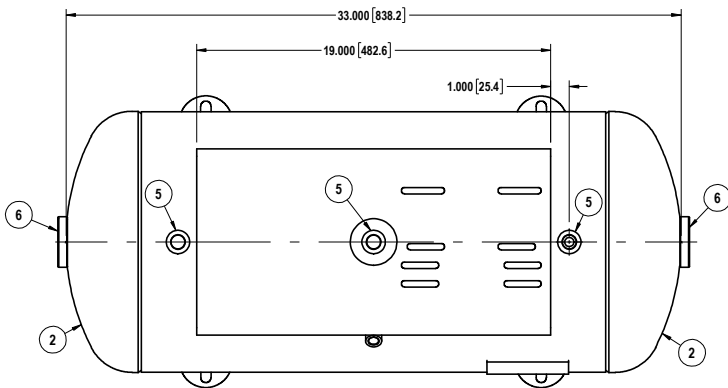
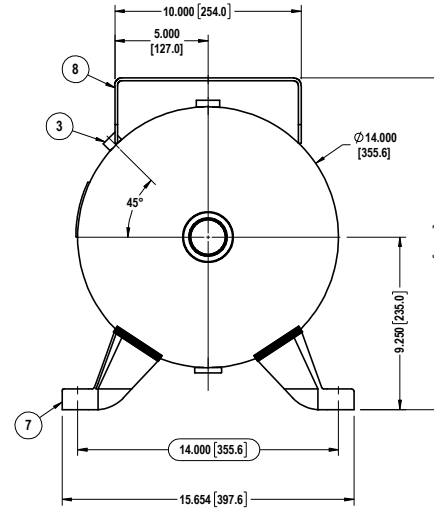
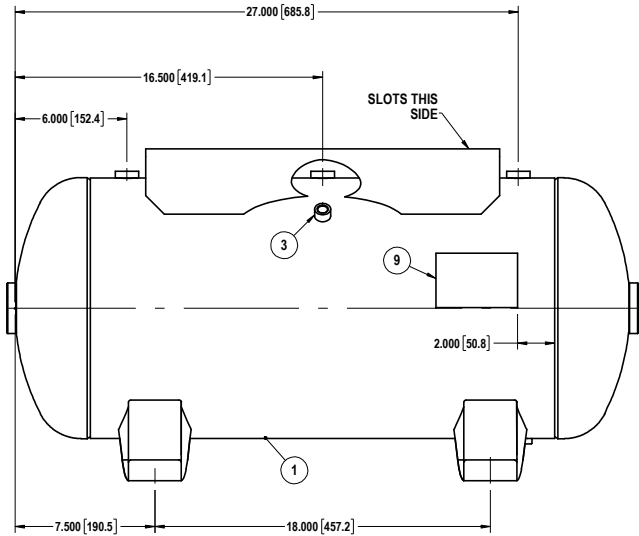

ITEM#	DESCRIPTION	QTY.
9	NAME PLATE	1
8	TOP PLATE	1
7	LEG	4
6	1-1/2" NPT COUPLING	2
5	1/2" NPT COUPLING	3
4	1/4" NPT FLAT COUPLING	1
3	1/4" NPT COUPLING	1
2	HEAD	2
1	SHELL	1

MORGANTON

-ASME-
20 GALLON
HORIZONTAL AIR RECEIVER
SECT. VIII DIV. 1

TOLERANCES, IF NOT INDICATED, ACCORDING TO:
C-G SE 03.03 / 3

DWG. NO.
VES04771

NOT FOR PRODUCTION USE