

THIS DRAWING & SPECIFICATIONS ARE PROPERTY OF MORGANTON PRESSURE VESSELS AND MAY NOT BE COPIED, REPRODUCED, OR USED IN WHOLE OR PART, AS A BASIS FOR DESIGN MANUFACTURE OR SALE WITHOUT PRIOR PERMISSION FROM MORGANTON PRESSURE VESSELS.

DESIGN INFORMATION	
SPECIFICATION	VALUE
DIAMETER (O.D.)	20.000"
MAWP	200 PSI AT 650°F
MDMT	-20°F AT 200 PSI
CAPACITY	APPROX 60 GALLONS
APPROX. WEIGHT	147 LBS

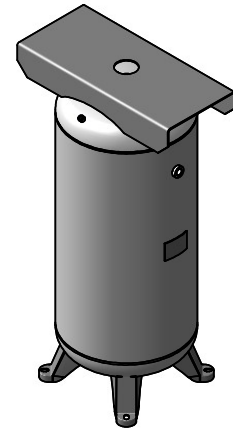
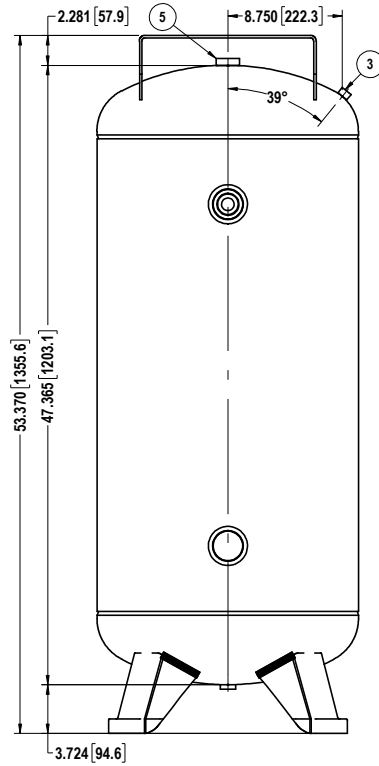
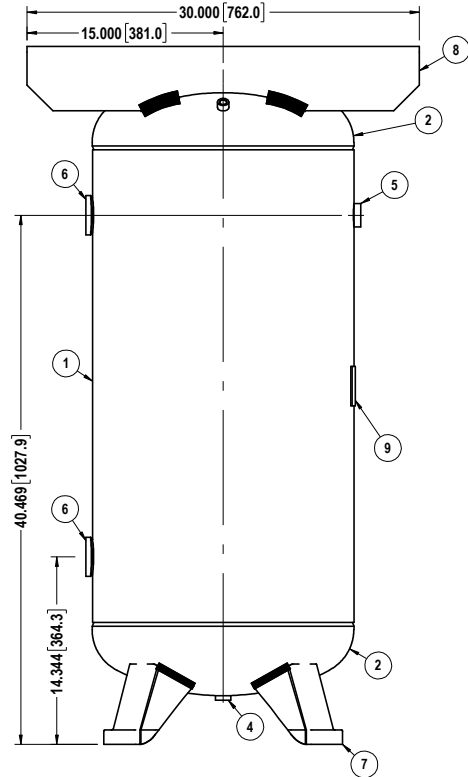
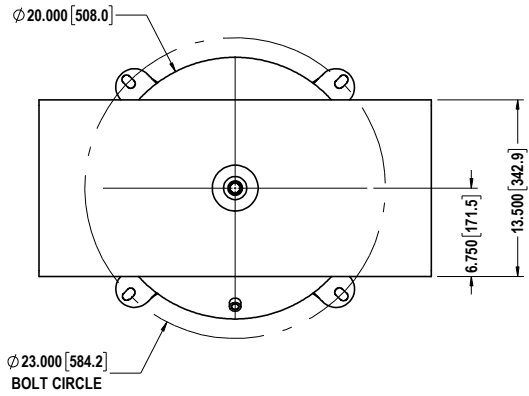

ITEM#	DESCRIPTION	QTY.
9	NAME PLATE	1
8	TOP PLATE	1
7	LEG	4
6	2" NPT COUPLING	2
5	3/4" NPT COUPLING	2
4	1/2" NPT COUPLING	1
3	1/4" NPT COUPLING	1
2	HEAD	2
1	SHELL	1

 60 GALLON VERTICAL VESSEL -ASME- SEC. VIII DIV. 1	TOLERANCES, IF NOT INDICATED, ACCORDING TO: C-G SE 03.03 / 3
	DWG. NO. VES04772
	REV. 2

NOT FOR PRODUCTION USE