

THIS DRAWING & SPECIFICATIONS ARE PROPERTY OF MORGANTON PRESSURE VESSELS AND MAY NOT BE COPIED, REPRODUCED, OR USED IN WHOLE OR PART, AS A BASIS FOR DESIGN, MANUFACTURE, OR SALE WITHOUT PRIOR PERMISSION FROM MORGANTON PRESSURE VESSELS.

DESIGN INFORMATION	
SPECIFICATION	VALUE
DIAMETER (O.D.)	36.000"
MAWP	200 PSI AT 650°F
MDMT	-20°F AT 200 PSI
CAPACITY	APPROX 400 GALLONS
APPROX. WEIGHT	878 LBS

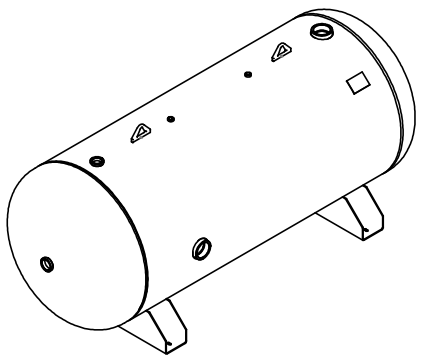
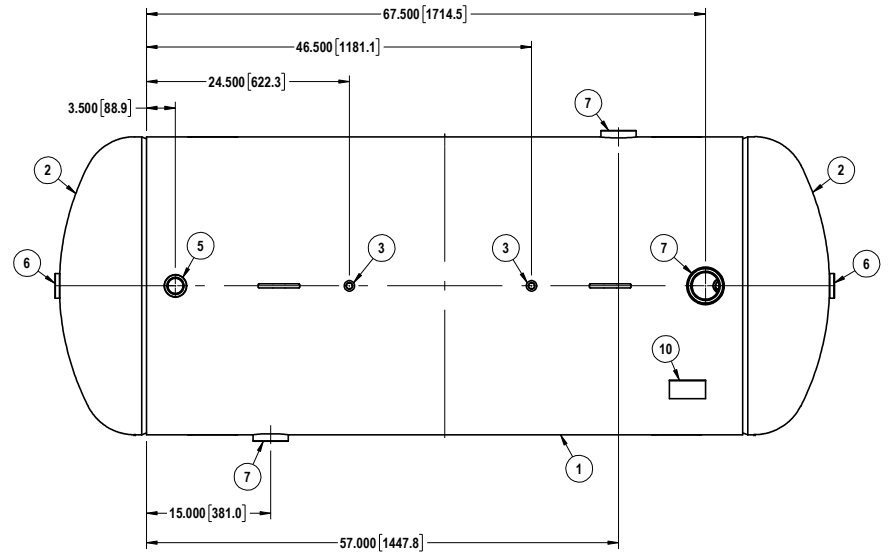
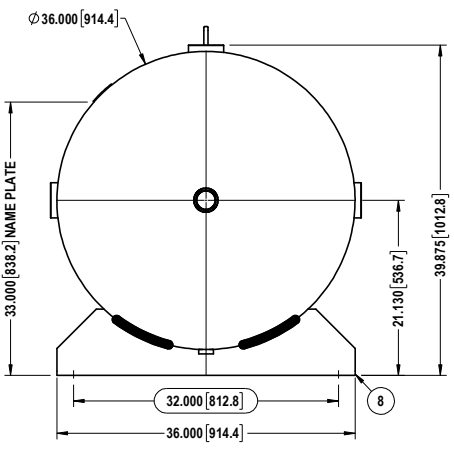
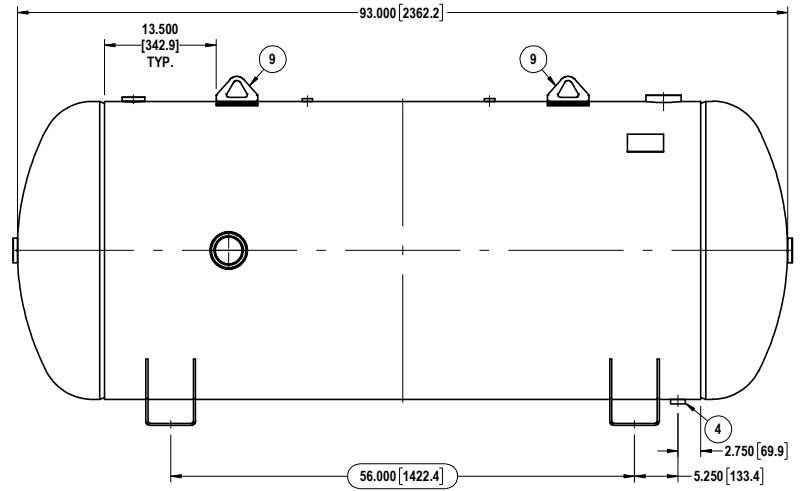

ITEM#	DESCRIPTION	QTY.
10	NAME PLATE	1
9	LIFTING LUG	2
8	SADDLE	2
7	3" NPT HALF COUPLING	3
6	2" NPT COUPLING	2
5	1-1/2" NPT COUPLING	1
4	3/4" NPT COUPLING	1
3	1/2" NPT COUPLING	2
2	HEAD	2
1	SHELL	1

**MORGANTON**  
 -ASME-  
 SECTION VIII DIV. 1  
 400 GALLON  
 HORIZONTAL VESSEL

TOLERANCES, IF NOT INDICATED, ACCORDING TO:  
 C-G SE 03.03 / 3

DWG. NO. **VES09076**

NOT FOR PRODUCTION USE