

THIS DRAWING & SPECIFICATIONS ARE PROPERTY OF MORGANTON PRESSURE VESSELS AND MAY NOT BE COPIED, REPRODUCED, OR USED IN WHOLE OR PART, AS A BASIS FOR DESIGN, MANUFACTURE, OR SALE WITHOUT PRIOR PERMISSION FROM MORGANTON PRESSURE VESSELS.

DESIGN INFORMATION	
SPECIFICATION	VALUE
DIAMETER (O.D.)	30.000"
MAWP	200 PSI AT 650°F
MDMT	-20°F AT 200 PSI
CAPACITY	APPROX 200 GALLONS
APPROX. WEIGHT	460 LBS

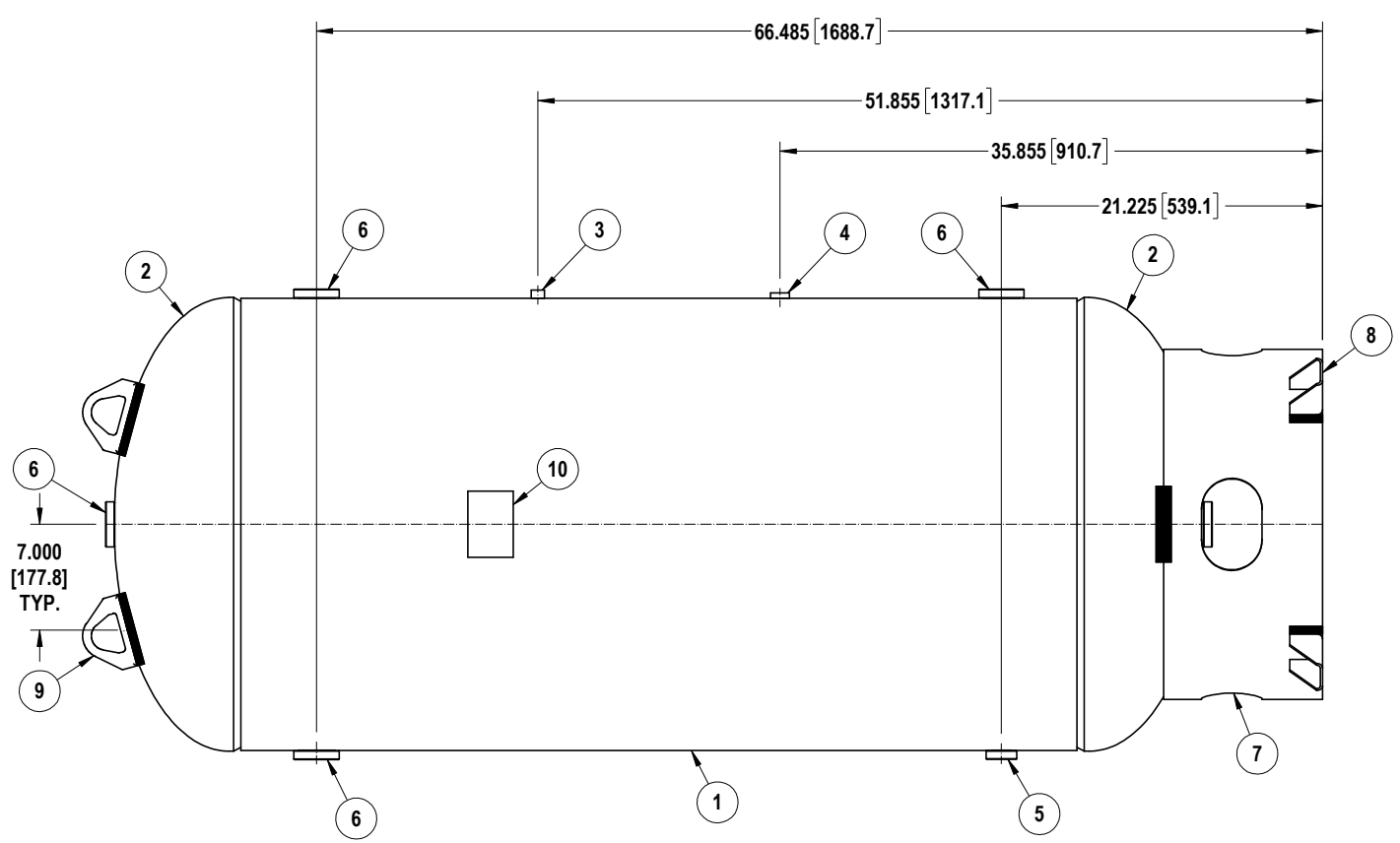
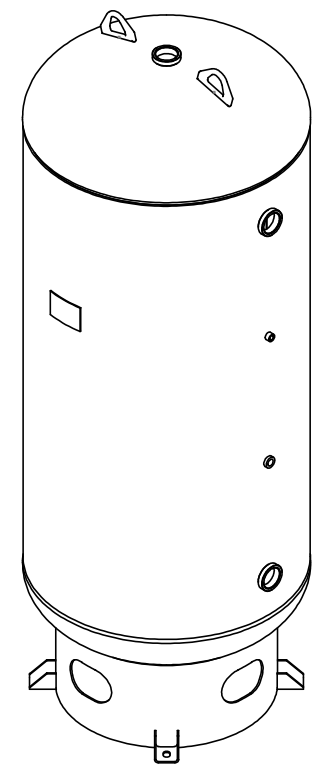
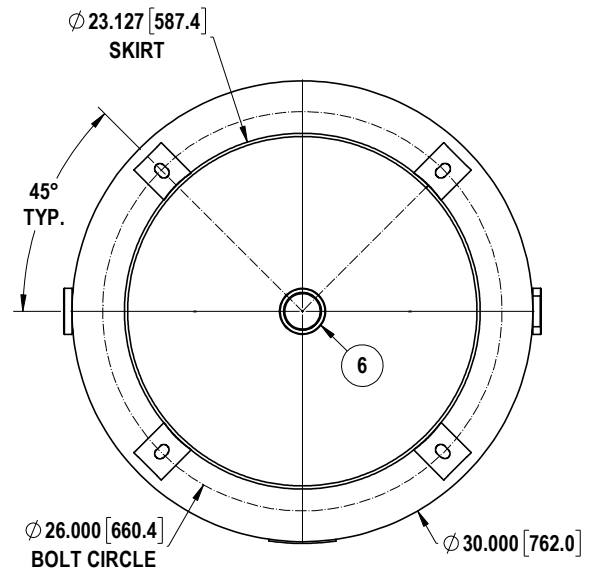
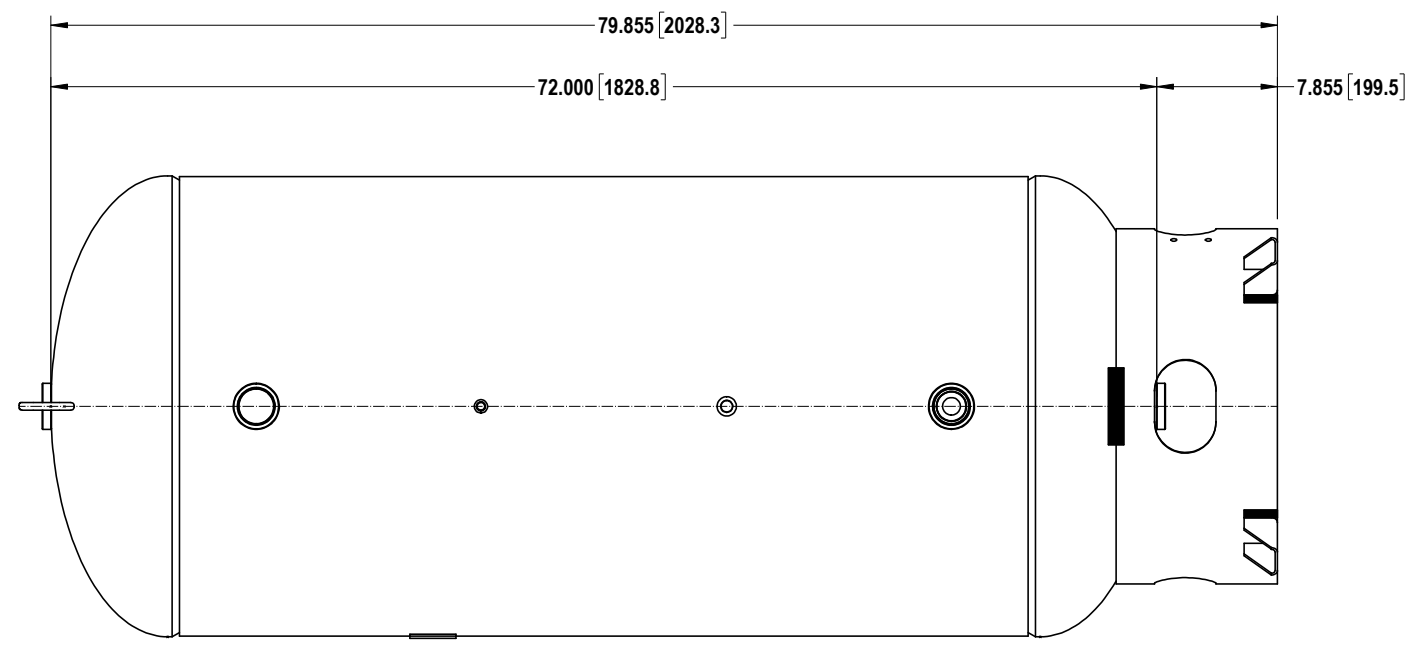

ITEM#	DESCRIPTION	QTY.
10	NAME PLATE	1
9	LIFTING LUG	2
8	SKIRT SUPPORT	4
7	SKIRT	1
6	2" NPT COUPLING	5
5	1" NPT COUPLING	1
4	1/2" NPT COUPLING	1
3	1/4" NPT COUPLING	1
2	HEAD	2
1	SHELL	1

NOT FOR PRODUCTION USE

MORGANTON TOLERANCES, IF NOT INDICATED, ACCORDING TO:
 -ASME- SECTION VIII DIV. 1
 200 GALLON VERTICAL AIR RECEIVER
 DWG. NO. **VES09298**
 NOT FOR PRODUCTION USE