

# Horizontal Grasshopper Tanks / 30-240 Gallons

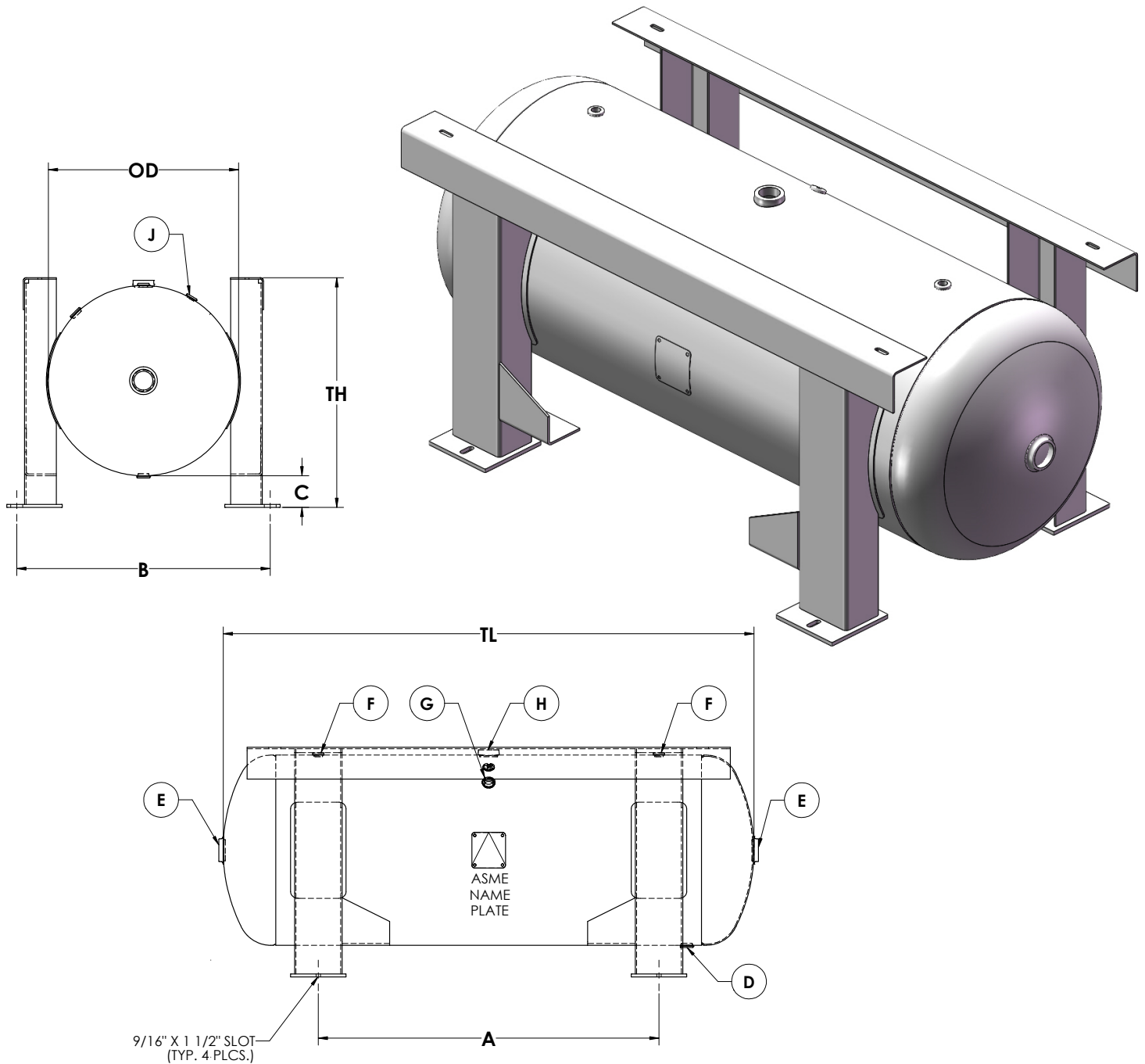

Pressure Vessel & Air Receiver drawings available for download, visit [manchestertank.com](http://manchestertank.com).

NOM CAP		Part #	MAWP	TW*	DIMENSIONS IN INCHES						NPT OPENINGS					
Gal	Cu Ft				OD	TL	TH	A	B	C	D	E	F	G	H	J
30	4.01	305438	200	125	16	38	21	22	22.0	4	1/4	1 1/2	1/2	3/4	1 1/2	1/8
60	8.02	305439	200	221	20	48	25	27	26.5	4	3/4	2	1/2	3/4	1 1/2	1/8
80	10.70	305440	200	273	20	63	25	42	26.5	4	3/4	2	1/2	3/4	1 1/2	1/8
120	16.04	302481	200	441	24	67	29	43	32.0	4	3/4	2	1/2	3/4	1 1/2	1/8
200	26.74	302643	200	743	30	72	35	42	40.0	4	1	2	1/2	3/4	1 1/2	1/8
240	32.09	302652	200	824	30	84	35	54	40.0	4	1	2	1/2	3/4	1 1/2	1/8

\*Tank weight pounds is calculated, may vary slightly.