

Horizontal Air Receivers / 400-2,560 Gallons

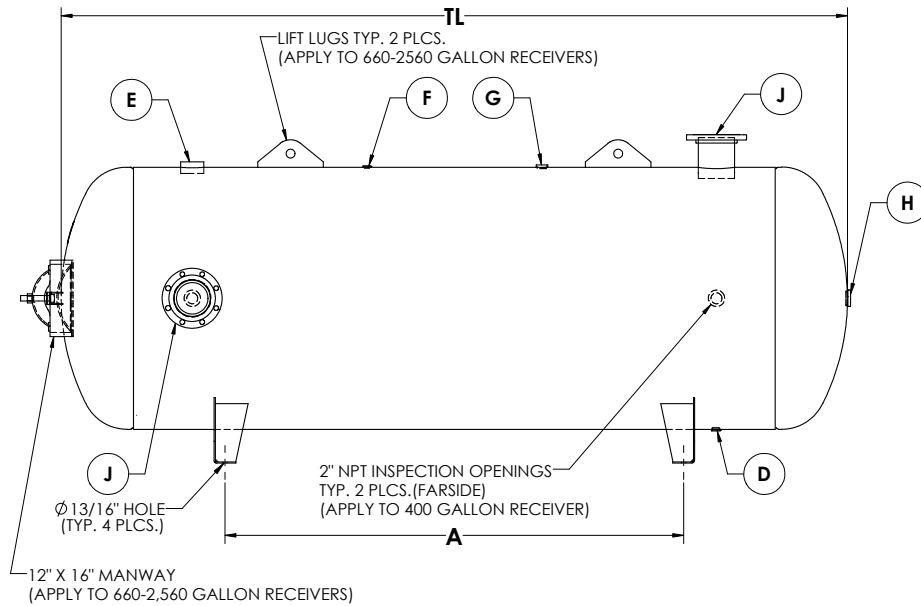
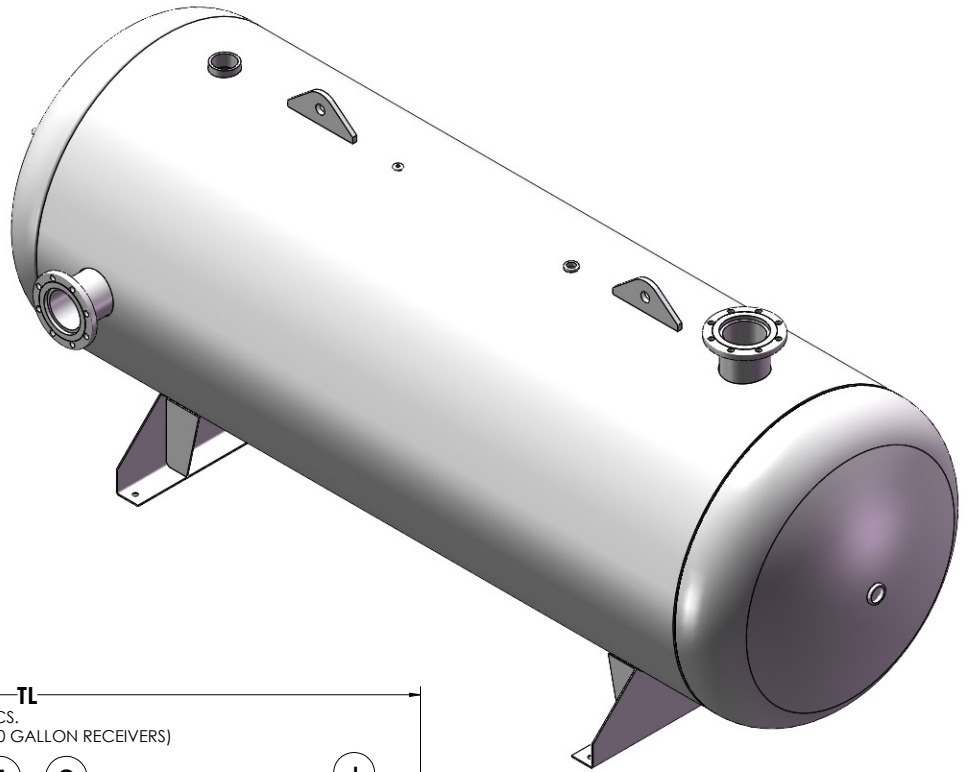
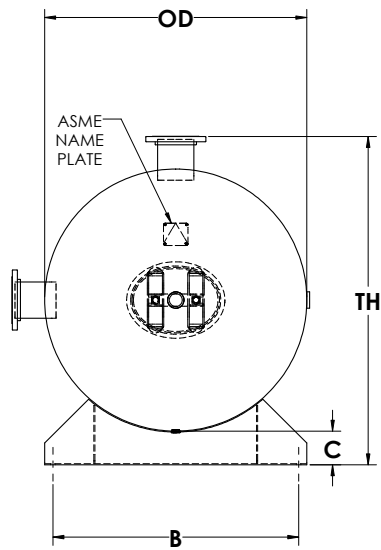

Pressure Vessel & Air Receiver drawings available for download, visit manchestertank.com.

NOM CAP		Part #	MAWP	TW*	DIMENSIONS IN INCHES						NPT OPENINGS					
Gal	Cu Ft				OD	TL	TH	A	B	C	D	E	F	G	H	J
400	53.48	302487	165	667	36	93	42	52	33	6	3/4	1 1/2	1/4	1/2	2	3
400	53.48	302488	200	744	36	93	42	52	33	6	3/4	1 1/2	1/4	1/2	2	3
660	88.23	302490	165	1386	42	117	48	70	39	6	3/4	3	1/4	1	2	3
660	88.23	302491	200	1445	42	117	48	70	39	6	3/4	3	1/4	1	2	3
1060	141.71	302493	165	2000	48	144	60	84	45	6	3/4	3	1/4	1	2	6" RFSO
1060	141.71	302494	200	2135	48	144	60	84	45	6	3/4	3	1/4	1	2	6" RFSO
1550	207.2	302496	165	2600	54	166	66	98	51	6	3/4	3	1/4	1	2	6" RFSO
2200	294.1	302498	165	4036	60	190	72	116	57	6	3/4	3	1/4	1	2	6" RFSO
2560	342.22	302500	165	4336	60	220	72	131	57	6	3/4	3	1/4	1	2	6" RFSO

*Tank weight pounds is calculated, may vary slightly.