



MidFlow Regulators

R37

SPECIFICATIONS

- Body**
 - Black coated aluminum
- Bonnet**
 - Glass filled nylon
- Seals**
 - Buna N Elastomer standard
- Seat**
 - Brass

KITS

- Repair Kits**
 - Diaphragm kit relieving DK35
 - Diaphragm kit Non-relieving DK35N
 - Valve kit VK37
- Mounting Kits** see page 65
 - Bracket kit RBK7
 - Panel mounting kit ring only panel hole size 1³/₁₆" PKR35
 - Panel mount bracket and ring PMKR35

FEATURES

- Micro finished brass seat to ensure no reduced pressure creep
- Reinforce diaphragm for repeated accuracy
- Minimal pressure droop due to efficient aspiration
- Three position non-rising adjustment knob; push to lock, pull to adjust, detach to make tamper resistant
- Relieving style standard
- Easily panel mounted
- Tamper-proof cap included
- High scfm flow due to efficient aspiration

OPTIONS

- add suffix to part number in alpha order
- G** Gauge (0-160 psi) R373G
 - H** High pressure 10 to 250 psi adjustment - *Must use T-handle option*
 - I** Instrument pressure 3 to 20 psi adjustment R373I
 - L** Low pressure 3 to 60 psi adjustment R373L
 - N** Non-relieving R373N
 - P** Panel mount R373P
 - T** Tee handle adjustment R373T

- Supply Pressure**
 - 250 psig
- Operating Pressure Range**
 - 5 to 125 psig
- Operating Temperature Range**
 - 40°F to 120°
- Gauge Port**
 - 1/4" full flow

PERFORMANCE CHARACTERISTICS

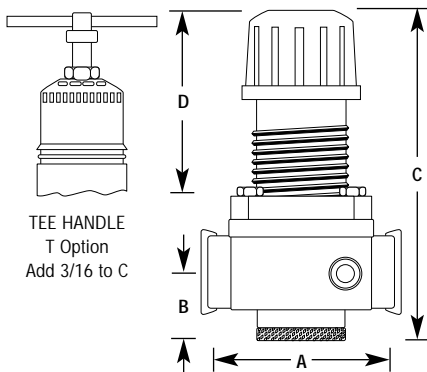
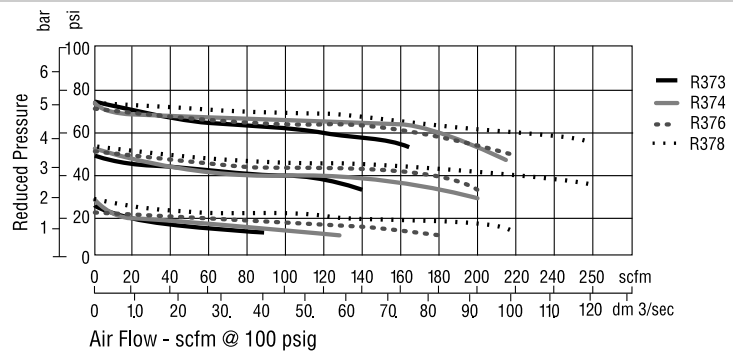

DIMENSIONS

PIPE SIZE	MODEL NO.	MAX. FLOW SCFM	DIMENSIONS (INCHES)					WEIGHT (LBS.)
			A	B	C	D	E (WIDTH)	
3/8"	R373	170	3 ⁷ / ₁₆	1 ¹³ / ₃₂	5 ⁷ / ₈	2 ³ / ₄	2 ¹ / ₄	1.3
1/2"	R374	215	3 ⁷ / ₁₆	1 ¹³ / ₃₂	5 ⁷ / ₈	2 ³ / ₄	2 ¹ / ₄	1.3
3/4"	R376	220	3 ⁷ / ₁₆	1 ¹³ / ₃₂	5 ⁷ / ₈	2 ³ / ₄	2 ¹ / ₄	1.3
1"	R378	250	3 ⁷ / ₁₆	1 ¹³ / ₃₂	5 ⁷ / ₈	2 ³ / ₄	2 ¹ / ₄	1.3